

Friedreich Ataxia: Update

April 1, 2016

David R. Lynch, MD PhD

Friedreich Ataxia (FA)

- Nicolaus Friedreich first described in 1860's based on 6 patients from 2 families
- A rare, genetic condition that is a progressive degenerative disease of children, adolescents and adults
 - Affects 1 in 50,000
 - *Estimated 5-6,000 individuals in US and 10-15,000 worldwide*
- Typically thought of as a neurodegenerative disease as this is the most visible and common symptom; however FA is a multi-system disease



FA – Clinical Features

Clinical features: Neuro

- Loss of large sensory neurons - proprioception
 - Loss of balance and coordination
 - Loss of reflexes
- Loss of spinocerebellar tracts
 - Loss of balance and coordination
- Loss of motor tracts to a lesser degree
- Loss of dentate nucleus of the cerebellum
 - Dysarthria (slurred speech), modest eye movement abnormalities
- Loss of a few other specific sites
 - Vision, hearing loss
- Sparing of cerebellar cortex, cerebral cortex
 - Normal cognition
- Overall loss of relatively few neurons, modest number of axonal tracts----MRI scans are normal or almost normal in early disease

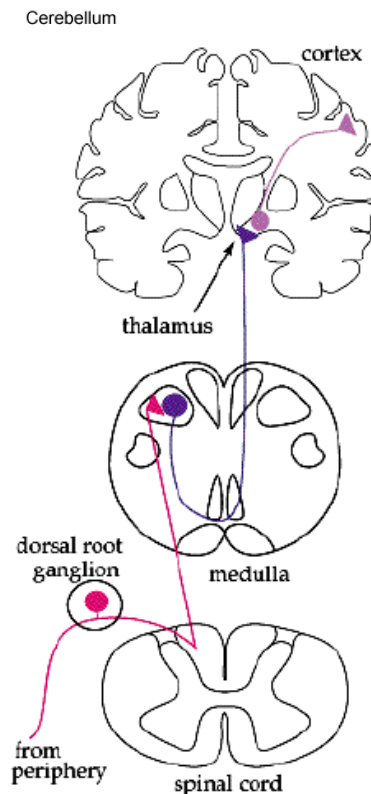
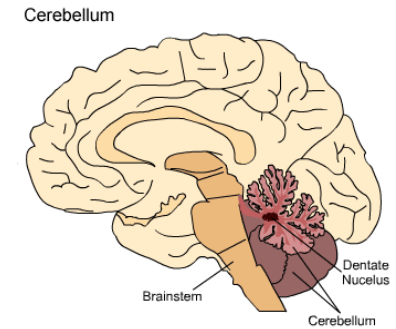

FA – Clinical Features

- Heart: Cardiomyopathy and arrhythmia
 - Hypertrophic cardiomyopathy
 - Later onset of progressive cardiac fibrosis with loss of systolic function
 - Clinically insignificant EKG abnormality – inverted T waves
 - Clinically significant arrhythmia
 - Troponin abnormalities—meaning unclear
- ENT:
 - Hearing loss –subclinically abnormal >70%, clinical dx: 10-15% of patients
 - Impaired temporal processing
- Ophthal: Optic atrophy - present in 10% of pts
 - Fixation abnormalities common (square wave jerks, ocular flutter)
 - Loss of retinal ganglion cells; OCT



FA – Clinical Features

- Endo: Diabetes –10-20%
 - >65% Insulin resistance
- Skeletal: Scoliosis
 - Corrective surgery required in up to 50% of patients
 - Pes cavus
- GU: Urinary symptoms– 50% of adult patients
 - Urgency, sphincter dysynergia
- Psychiatric: Depression
- Fatigue: Nearly all patients experience significant fatigue that impacts quality of life
- Cognition: Remains essentially normal



FA – Monogenic condition, Autosomal recessive
 1996 – Disease causing gene identified, FXN

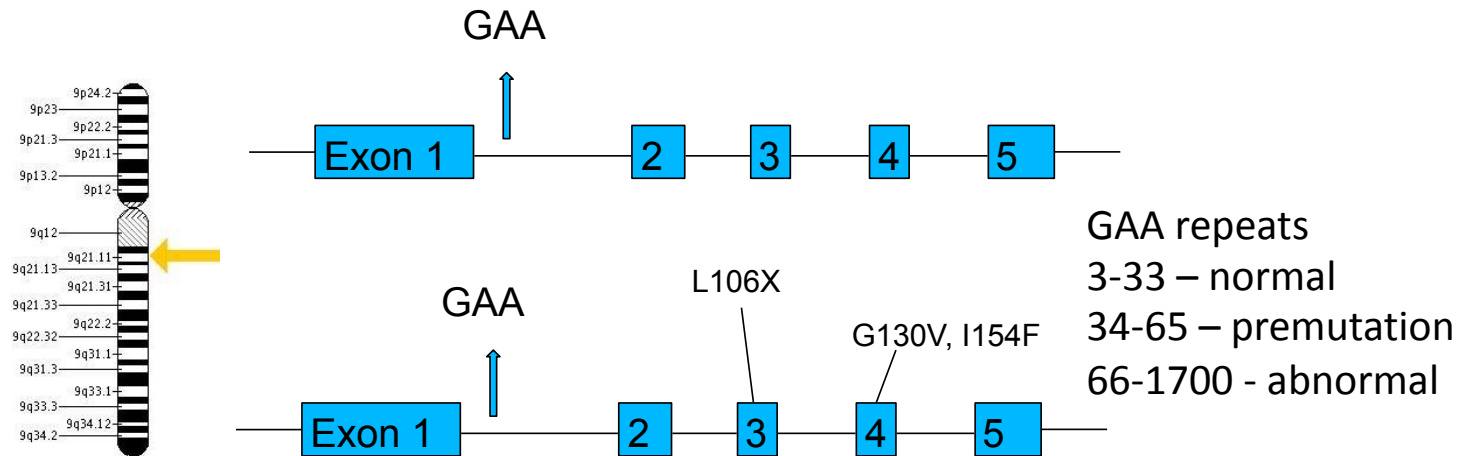

Primary disease causing mutation is the expansion of a naturally occurring GAA repeat in the noncoding region of the gene for frataxin (FXN) - 95% of abnormal alleles. The other 5% of abnormal alleles are point mutations in the coding regions of the gene.

ONE DOES NOT HAVE TO PUT IN NEW GENE, ONLY TURN THAT WHICH THERE ON

Mechanisms of FXN silencing by the expanded GAA repeat

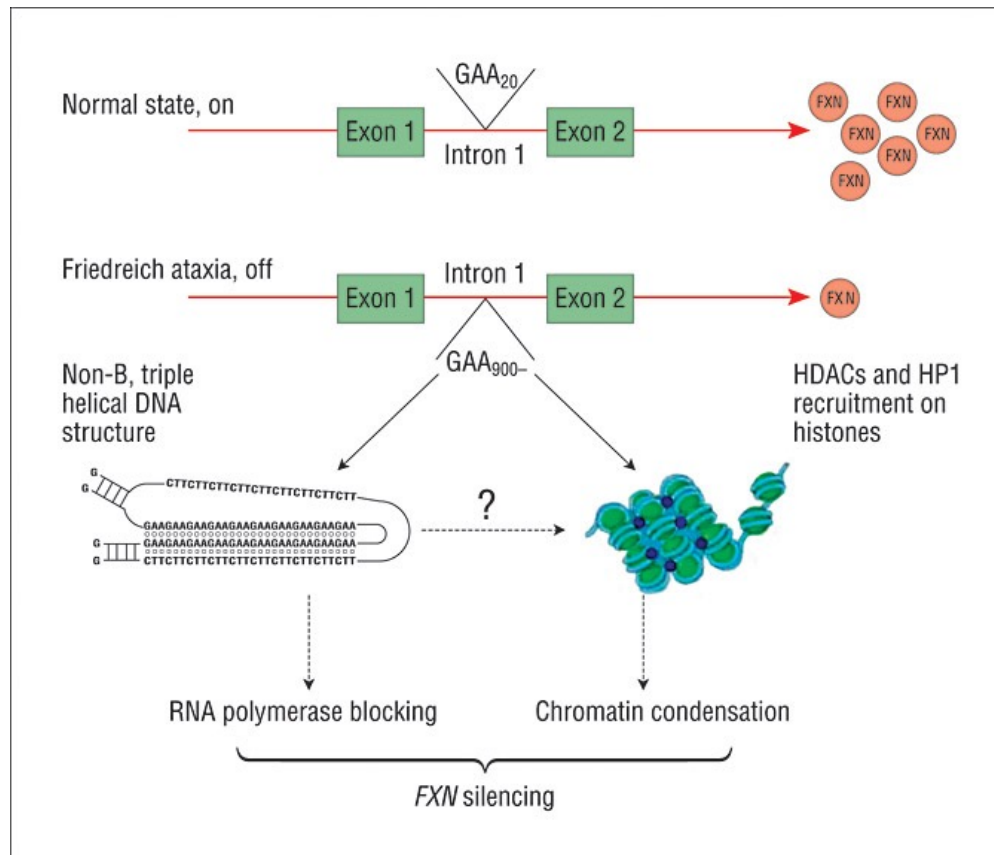

Pandolfo, M. Arch Neurol 2008;65:1296-1303.

Copyright restrictions may apply.

New concepts:

Other modifications of DNA such as methylation

Progressive

Potentially reversible by Small RNA molecules

ARCHIVES OF
NEUROLOGY

GAA Repeat Size and Age of Onset, Durr et al., NEJM, 1996

- GAA repeat expansion sizes correlate with measures of disease severity
- GAA repeat expansions decrease, but do not eliminate, frataxin expression
- This curve for 1997 looks the same now.

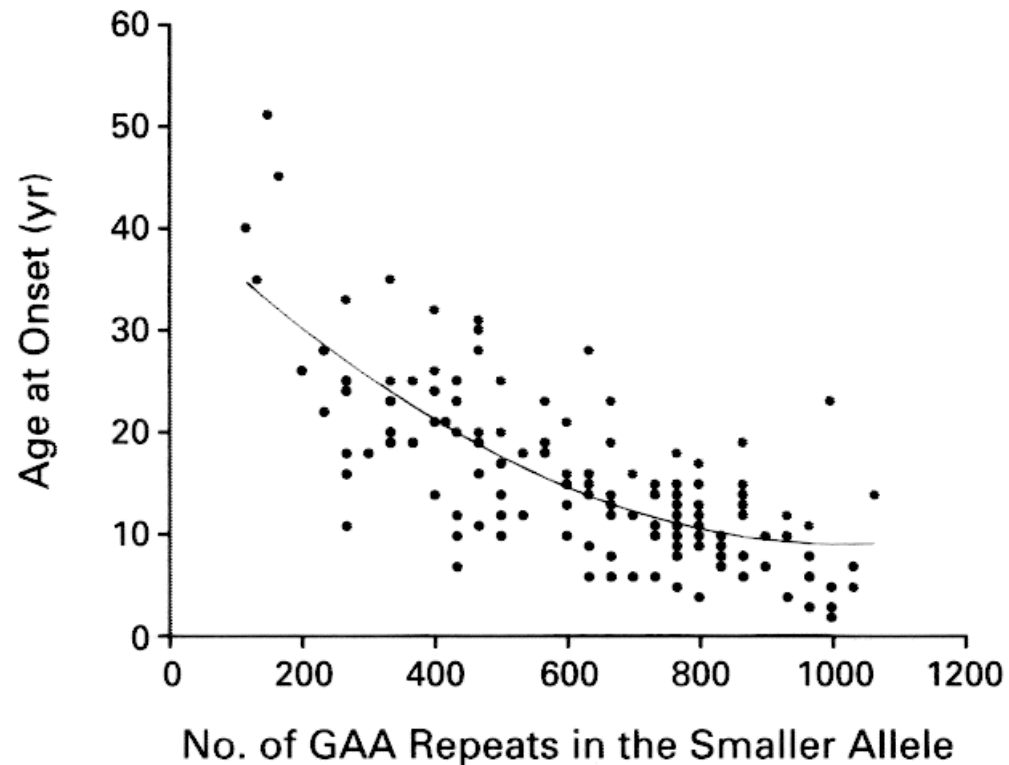

FRDA

- Pathophysiology
 - GAA expansions lead to gene silencing which leads to relative lack of frataxin
 - Frataxin deficiency leads to mitochondrial dysfunction
 - Cell selective mitochondrial dysfunction leads to clinical manifestations including neurological features.



FA TREATMENT PIPELINE – MARCH 2016

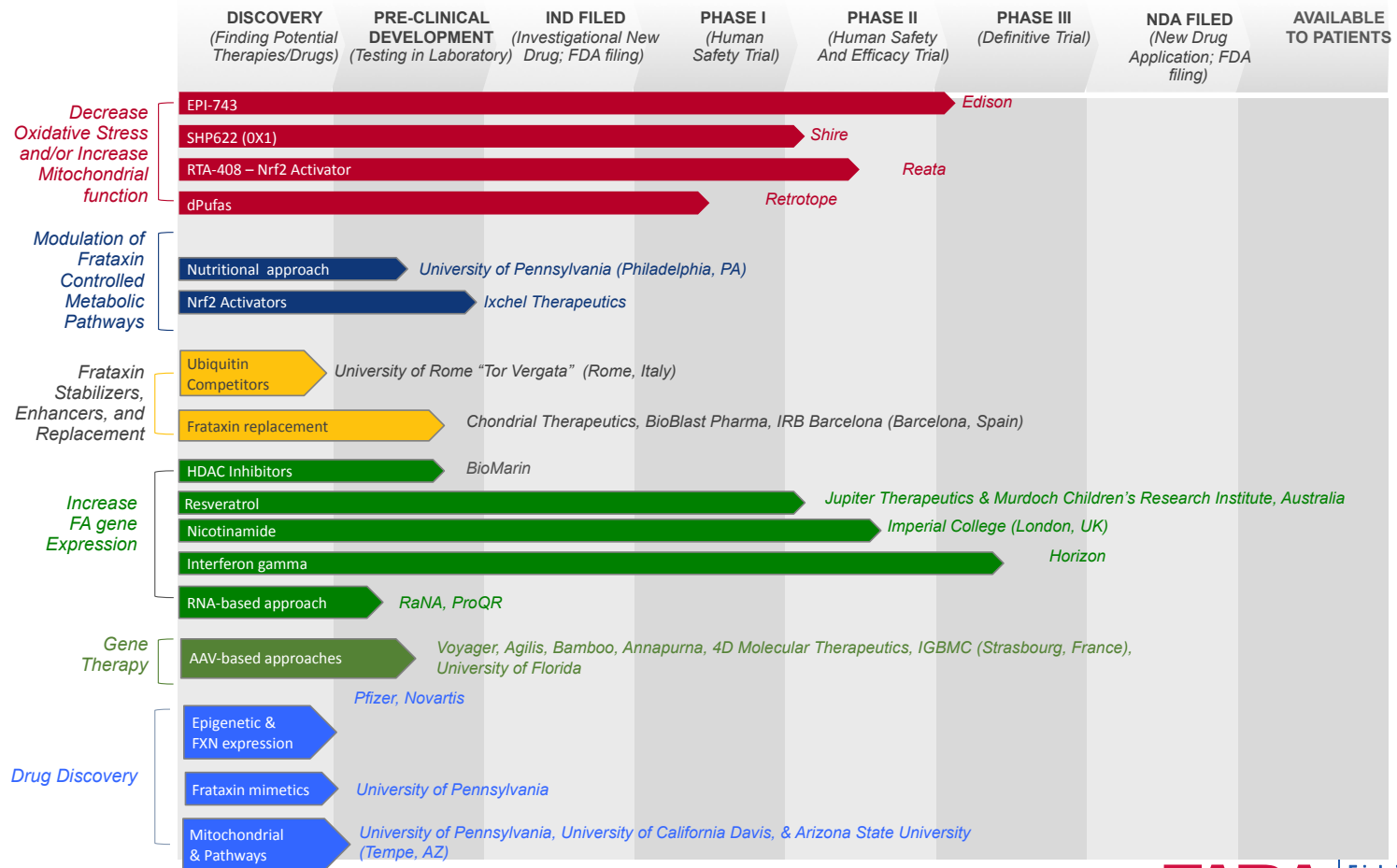

FRDA Therapies

- Conceptual approaches to clinical trials:
 - Improve mitochondrial function/antioxidant
 - EPI743
 - SH622
 - Idebenone,
 - CoQ
 - Retrotope RT001
 - Improve bodies reaction to Mitochondrial dysfunction
 - Reata RT 408
 - Make more frataxin



Ways to make more frataxin

- Turn gene back on
 - Inhibit processes turning off—HDAC, methylation
 - Use small RNA based therapies to turn on
 - Actimmune
- Give exogenous frataxin
 - TAT frataxin and similar approaches
- Put in a new gene
 - Gene therapy (at least 6 companies)
- Cut out the abnormal gene
 - CRISPR technology and others



Pathophysiology of FRDA



- Pathophysiology
 - GAA expansions lead to gene silencing which leads to relative lack of frataxin
 - Frataxin deficiency leads to mitochondrial dysfunction
 - Cell selective mitochondrial dysfunction leads to clinical manifestations including neurological features
- So what else do we need to test a drug neurologically?

FRDA

- Measures
 - Biomarkers
 - Natural history data
 - Way to find patients with specific features
 - Funding
-
- Patient advocacy organization
 - Pharmaceutical company support
 - CCRN, EFACTS



FA Biorepository (CHOP)

- DNA - >750 samples from patients
- RNA – 300 patients, 150 carriers, 50 controls
- Whole blood - >650 patients, 500 carriers, 200 controls
 - Frataxin measurement
- Plasma – 475 patients, 200 carriers, 80 controls
- Serum – 300 patients, 150 carriers, 75 controls
- Buccal cells – 700 patients, 500 carriers, 200 controls
 - Frataxin measurement
- Fibroblasts
 - Expanding fibroblast lines at Coriell
 - M.Napierala - >40 lines growing and establishing iPS cells
- Muscle biopsy

Neurological measure

Friedreich Ataxia Rating Scale

1. Quantified exam
2. Rate of change over time
know from natural history study
3. Acceptable to FDA in modified
form

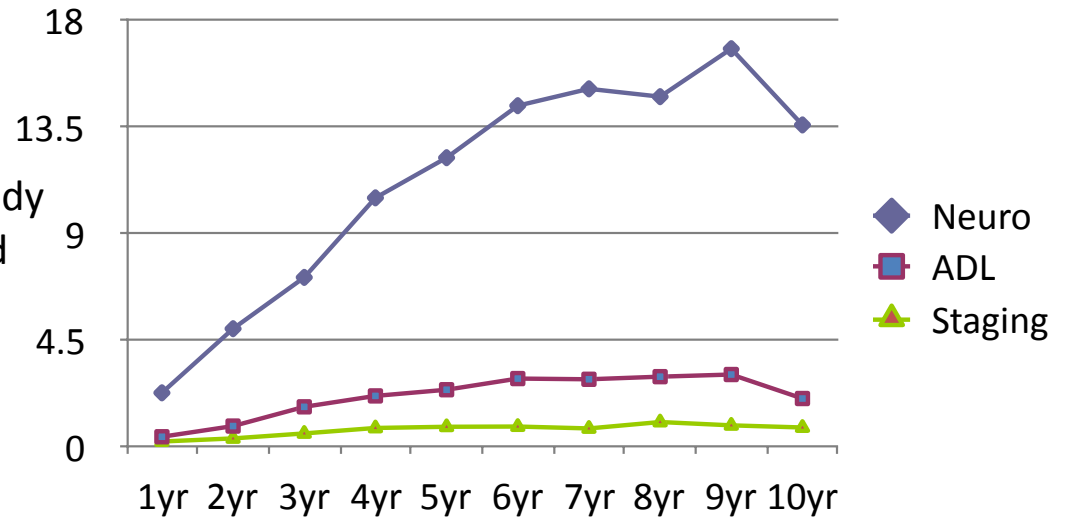

Can compare results from clinical trials to this curve as a control

Typical Anatomically selective measures

- Nerve conduction studies
 - Measure large proprioceptive neurons
 - Frequently absent in FA patients as soon as symptoms begin
 - Do not worsen over time if present
- Somatosensory evoked potentials
 - Measure large proprioceptive neurons
 - Frequently absent in FA patients as soon as symptoms begin
 - Do not worsen over time if present
- MRI scan
 - Normal brain early in FA
 - Spinal cord atrophy at presentation (reflecting large proprioceptive neurons)
- Conclusion: typical anatomic measures do not work well in FA

Methodologies for ongoing anatomical evaluation

- MRI
 - Minnesota
 - Brazil
- MRS
 - Minnesota
- Electrophysiological
 - Motor evoked potentials
 - Correlate with disease severity in FRDA



Motor Mapping: Transcranial Magnetic Stimulation

- A safe, well tolerated, noninvasive technique which uses electromagnetic fields to induce action potentials in motor neurons
- Assess the integrity of central motor pathways

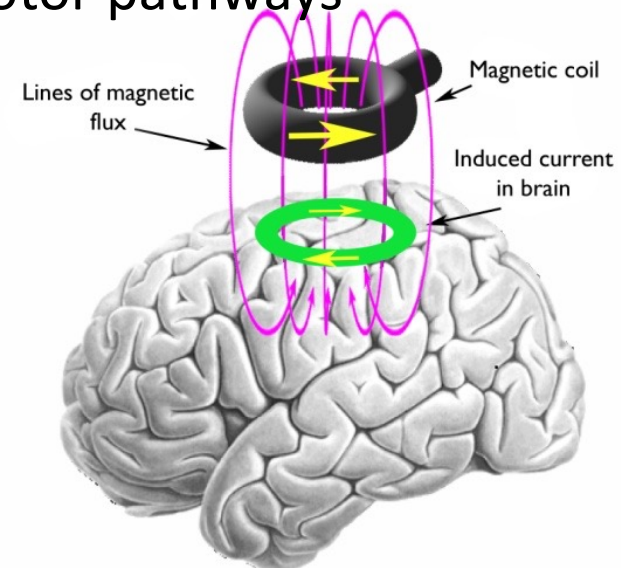



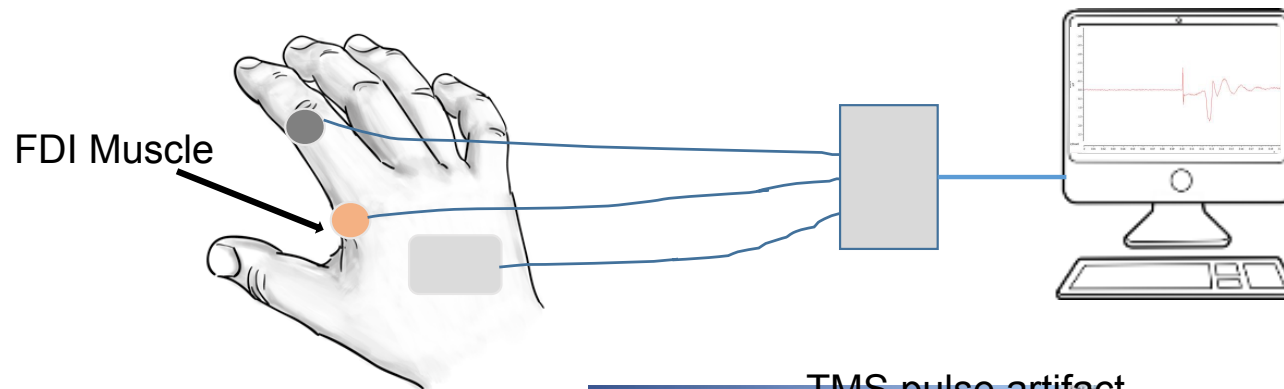

TMS pulse artifact

Motor Evoked Potential

Amplitude (mV)

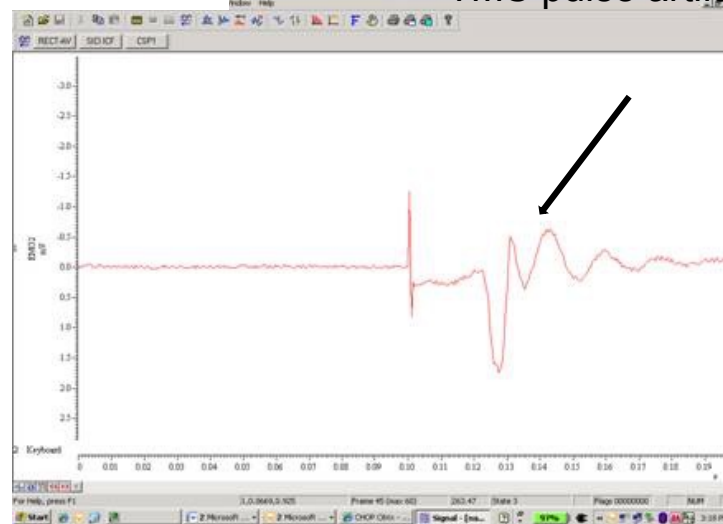

Time (seconds)

Conclusions

- Many agents coming to clinical trials for FRDA
- Need collaboration across all groups to develop novel tests